

LDZ 高速型組裝機器人第四代 - DR8020

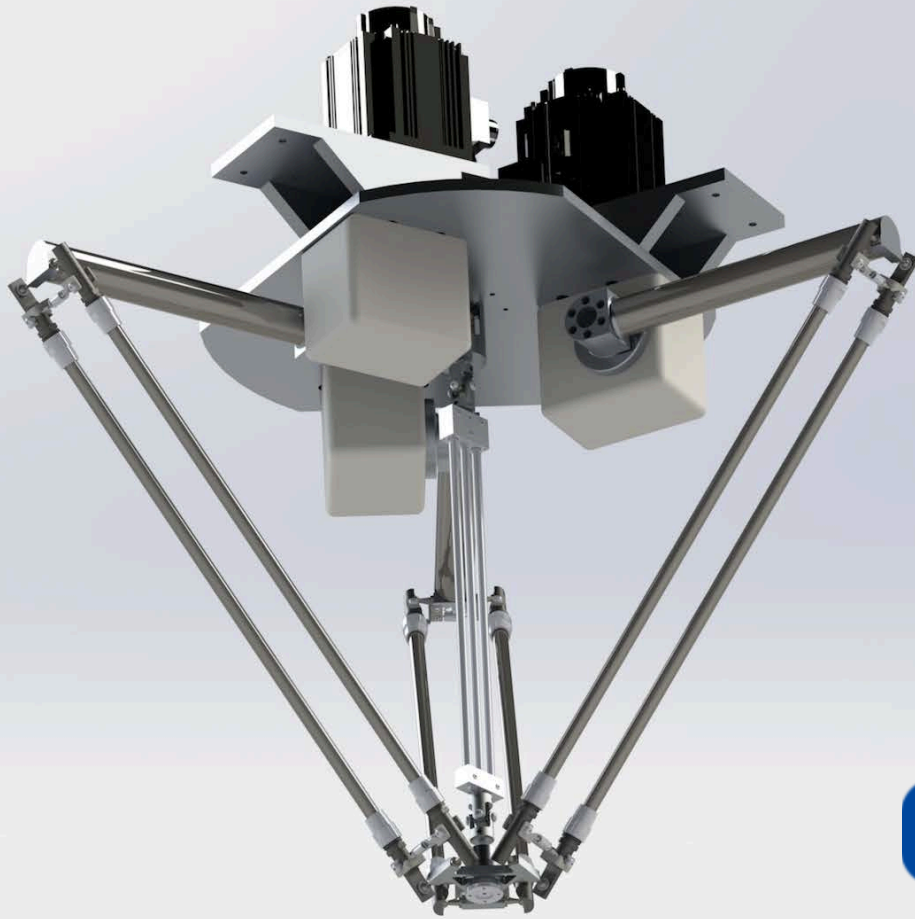

適用範圍

高速取放
高速組裝
高速整列
高速包裝

首創功能

可拆裝關節系統-長度可自行拆裝變換長度，運用於變化性較大的產品。

已申請專利編號：

專利字第TW M528839、UZJ09705/CX

特長

- MIT台灣製造，整合服務零時差。
- 全系統採用高速網路(Ethercat)。
- IP67結構設計(防塵、防撥水)。
- 可指定合乎食品衛生之素材、設計(選配)。
- 搭配視覺系統，提供智慧化功能(選配)。
- 多種通訊格式支援 (選配)

歡迎預約、現場測試

原廠:立達興科技股份有限公司

台北 (02)22953870 傳真:(02)22953771

公司地址:24858新北市五股區壟鈎 5-20號



LDZ Sniper 8020

Number of axis

3 Translational axes + 1 Optional Rotation Axis

Working Range

Horizontal stroke - 800mm

Vertical stroke - 200mm

Cycle time*

0.35s

Weight

40kg

Pated Payload

1kg

Repeatability

±0.1mm

Angular Repeatability

±1°

Speed

10m/s

Acceleration Speed

10G

Rated Current

15A

Rated Voltage

220V

Controller

OMRON NJ501-1300

Installation

Floor, ceiling

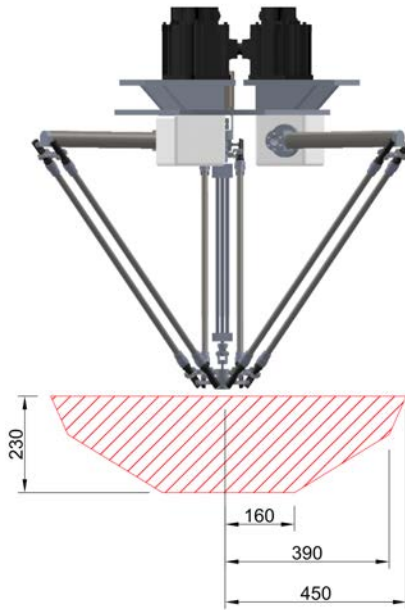

Working Range (mm)

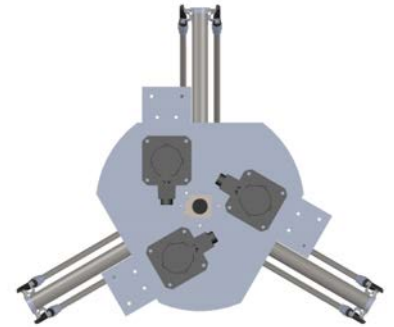

* Cycle time is based on a Payload 0.1 kg, reciprocating movement over a25/305/25 (mm). Actual cycle time will depend on operating conditions.

